

General fitting guide for radiators.

Radiator style and size
may vary depending
on model chosen.

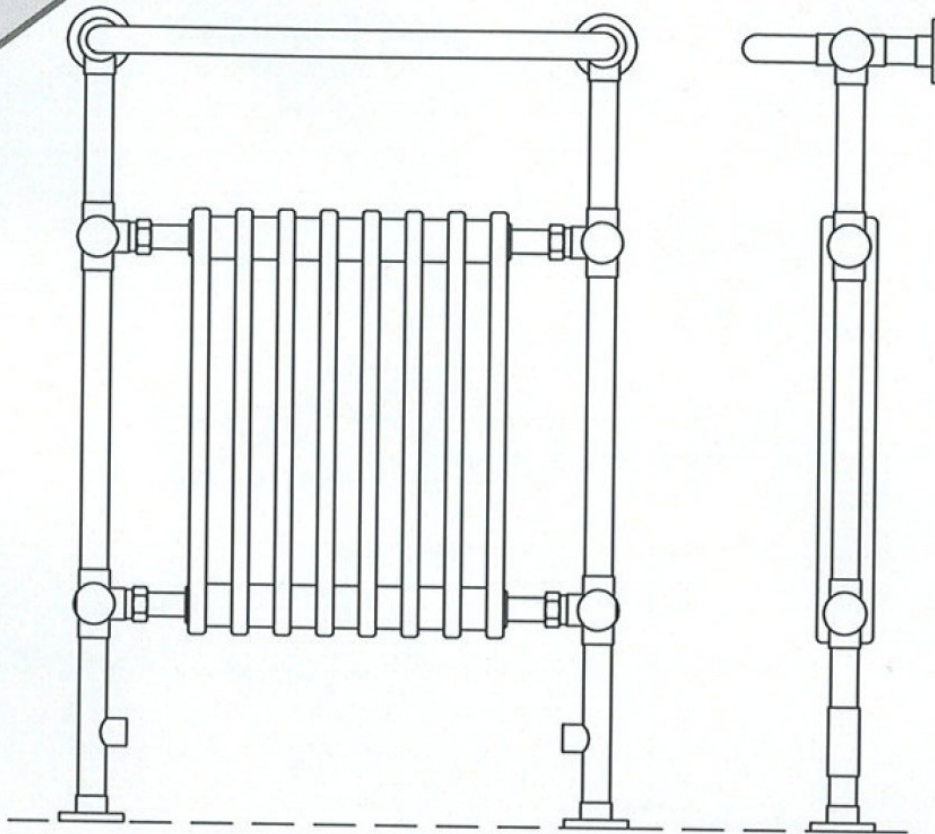

Consult a qualified plumber if you
have any problems installing this product.

Floor mounted

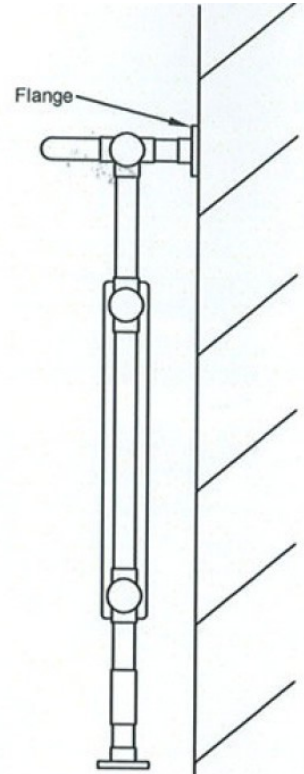
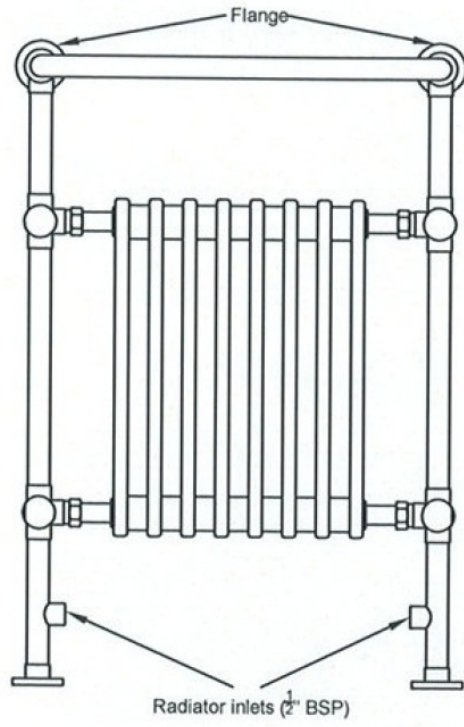

Wall mounted

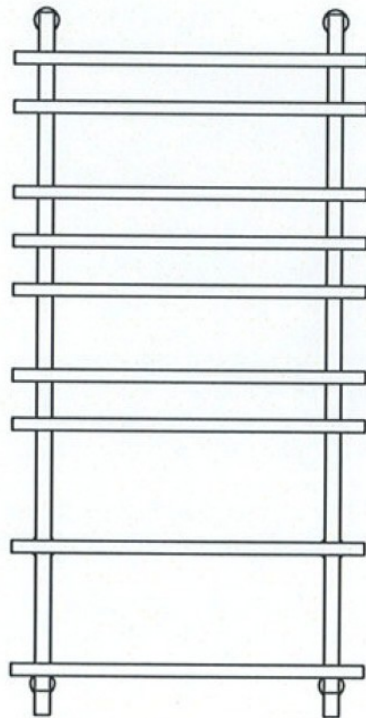

Radiator inlets (2" BSP)

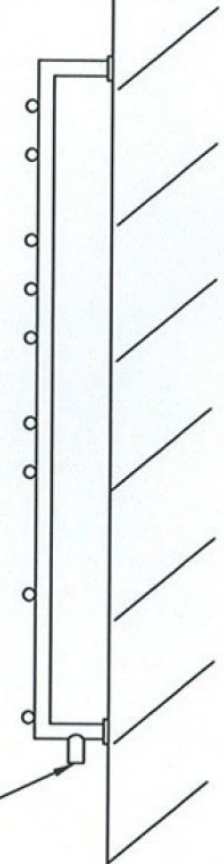

INTRODUCTION

The model supplied may vary from the image shown. For example, your chosen product may have different rail joint styles and middle panel insert (if fitted), or be wall mounted.

GUARANTEE AND AFTERCARE

During installation, extra care must be taken to avoid damaging the fitting or its finish. To maintain the appearance of the fitting, please ensure it is cleaned regularly using a clean soft damp cloth only. Abrasive cleaners or detergents must not be used as they may cause surface deterioration. We provide a ten year guarantee against faulty workmanship or materials (excluding serviceable parts), providing they have been installed, cared for and used in accordance with our instructions.

FITTING PROCEDURE (floor mounted)

1. Remove radiator and fixing kit from box.
2. Fix the top flanges to the radiator and secure with grub screw located underneath the rail. (if supplied, flanges are loose in box)
3. Offer the radiator up to the wall in the required place. Note: The radiator must be fitted against a flat wall and floor.
4. Mark out the hole positions for the screws on the wall and floor. There are 3 holes in each flange, or one brass fixing peg. (These come fitted into flanges on some models)
5. Drill holes in the wall and floor to suit the rawl plugs provided.
6. Fit the rawl plugs into the wall.
7. Remove the top flanges from the radiator by means of the grub screw underneath the rail. (only applies to radiators with removable flanges)
8. Screw the top flanges to the wall in the correct position. (alternatively, screw the fixing pegs to wall and floor)
9. Push the radiator back into the flanges and tighten the grub screws. (or push over fixing pegs)
10. Screw the radiator to the floor through the bottom flanges. (or tighten grub screws onto fixing pegs)
11. Hudson Reed radiator valves (not supplied) need to have a substantial length of PTFE tape wrapped around the thread, and then be screwed into the radiator inlets. (This is to create an adequate water seal, as per good plumbing practice)
12. Ensure that the inlets on the valves are pointing down towards the floor.
13. The copper inlet pipes are fed into the valves through the floor, and are secured to the valves by tightening the nut up (The copper olive will make a watertight seal.)
14. Check for leaks.

FITTING PROCEDURE (Wall mounted)

1. Remove radiator and fixing kit from box.
2. Remove the brass wall fixing pegs from the radiator. (These are inside the flanges)
3. Mark out the hole positions for the brass fixing pegs on the wall.
4. Drill holes and fix the pegs into position, using the screws and rawl plugs provided.
5. Push the radiator over the brass pegs, and secure the radiator using the grub screws located underneath the rail.
6. Hudson Reed radiator valves (not supplied) need to have a substantial length of PTFE tape wrapped around the thread, and then be screwed into the radiator inlets. (This is to create an adequate water seal.)
7. The copper inlet pipes are fed into the valves through the wall, (or floor) and are secured to the valves by tightening the nut up (The copper olive will make a watertight seal.)
8. Check for leaks.